

Article number: 230100044211
 Description: E+G Crank handle
 MT.80 AS-10x10-SI

Measures

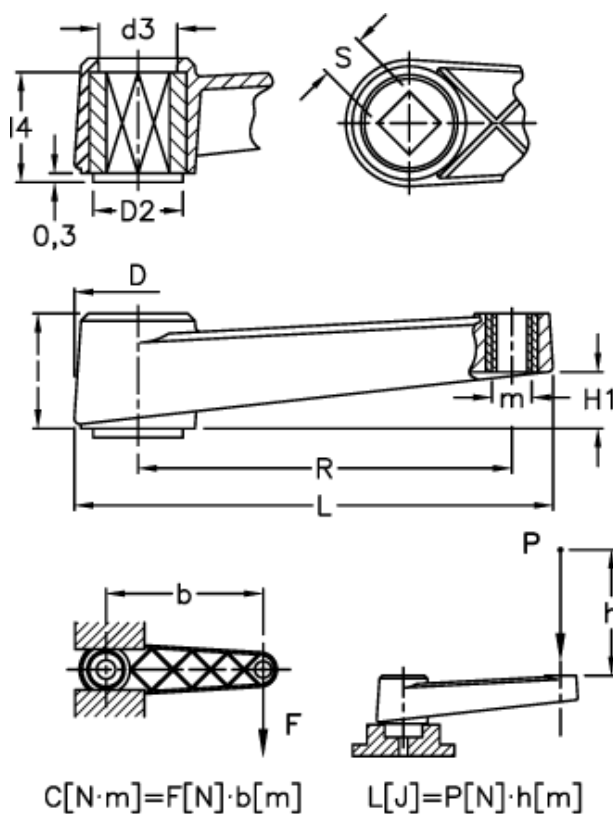

C (N m)	= 180	l4	= 22
D	= 30	m	= M6
d2	= 20	R	= 80
d3	= 17	S H9	= 10x10
H1	= 13		
l	= 26		
L	= 105		
L(J)	= 15		